

I-3001

compression cam latch

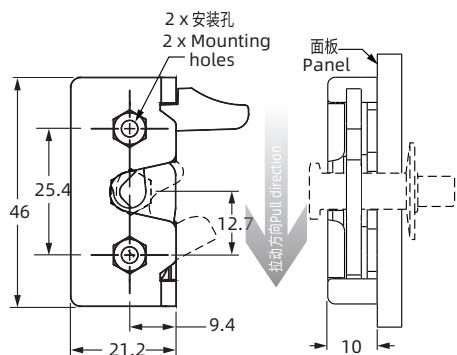

手动驱动 Hand Actuation



直接驱动 (仅限于钢质) Direct Actuation (Steel Only)

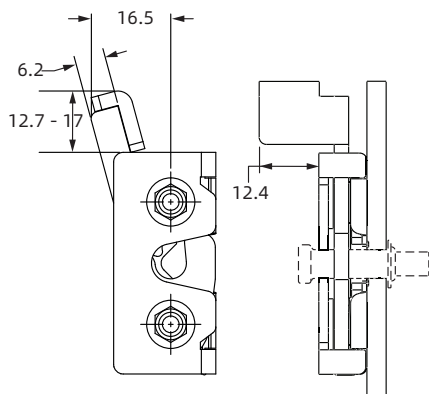

底部驱动 Bottom Actuation

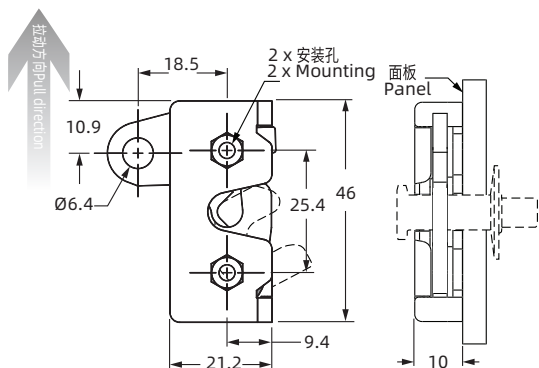

固定支架 Mounting Bracket (适用于所有钢质杆类型) (Option for all Lever Types in Steel)

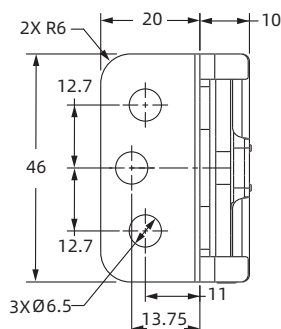

选型 Model selection

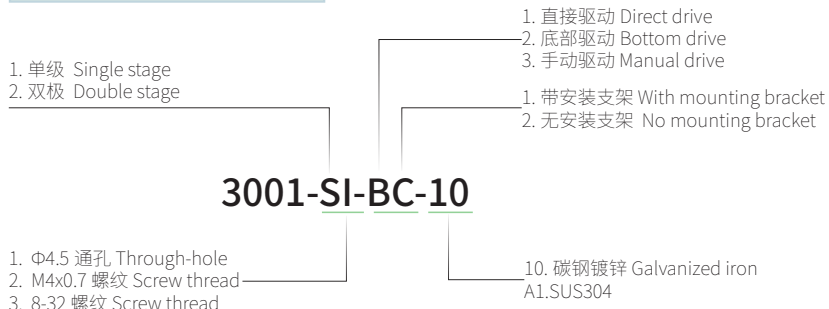

1. Material and surface treatment:
Main body: Steel, galvanized or zinc nickel or SUS304

1. 材质及表面处理:
主体: 钢, 镀锌或锌镍, 或 SUS304

如需获得产品 3D 模型图, 请联系 WWW.FORND.COM