

## A-1212

## Rod Control Swinghandle

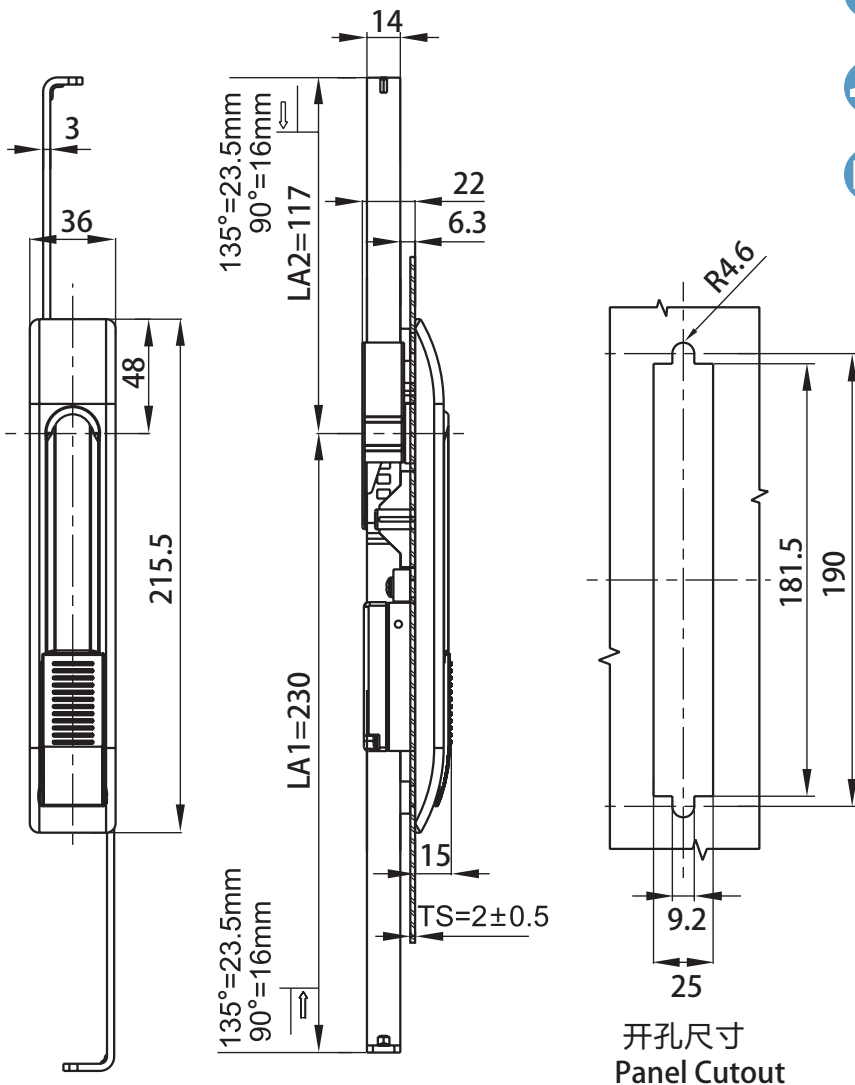

RL

IP65

IP65



开孔尺寸  
Panel Cutout

1. Material and surface treatment:  
Lock body: PA66+30%GF;  
handle: Zamak DIN-EN 1774-ZnAl40Cu1  
Steel bolt: iron galvanized  
Sealing ring: EPDM foam.

2. Performance parameters:  
Protection class: IP65  
Handle bearing tension value: ≤ 490N  
Handle bearing torque value: ≤ 26N.m

3. Remark:  
Key different on request  
CH751 key code on request

1. 材质及表面处理:  
锁体: PA66+30%GF  
手柄: 5#锌合金喷塑黑  
螺栓: 铁镀锌  
密封圈: EPDM发泡胶。

2. 性能参数:  
防护等级: IP65  
手柄承载力值: ≤ 490N  
手柄承载扭矩值: ≤ 26N.m

3. 备注: Remark  
专用钥匙可选  
CH751 钥匙可选

Version A( 锁舌型 Cam control)	Version C( 三点拉杆型 3Prod control)
麻面黑 Black textured powder coated	麻面黑 Black Textured powder coated
A-1212-1001-60	A-1212-3001-60