

# 连杆型旋转把手 Rod Control Swinghandle

## A-1201 Rod Control Swinghandle

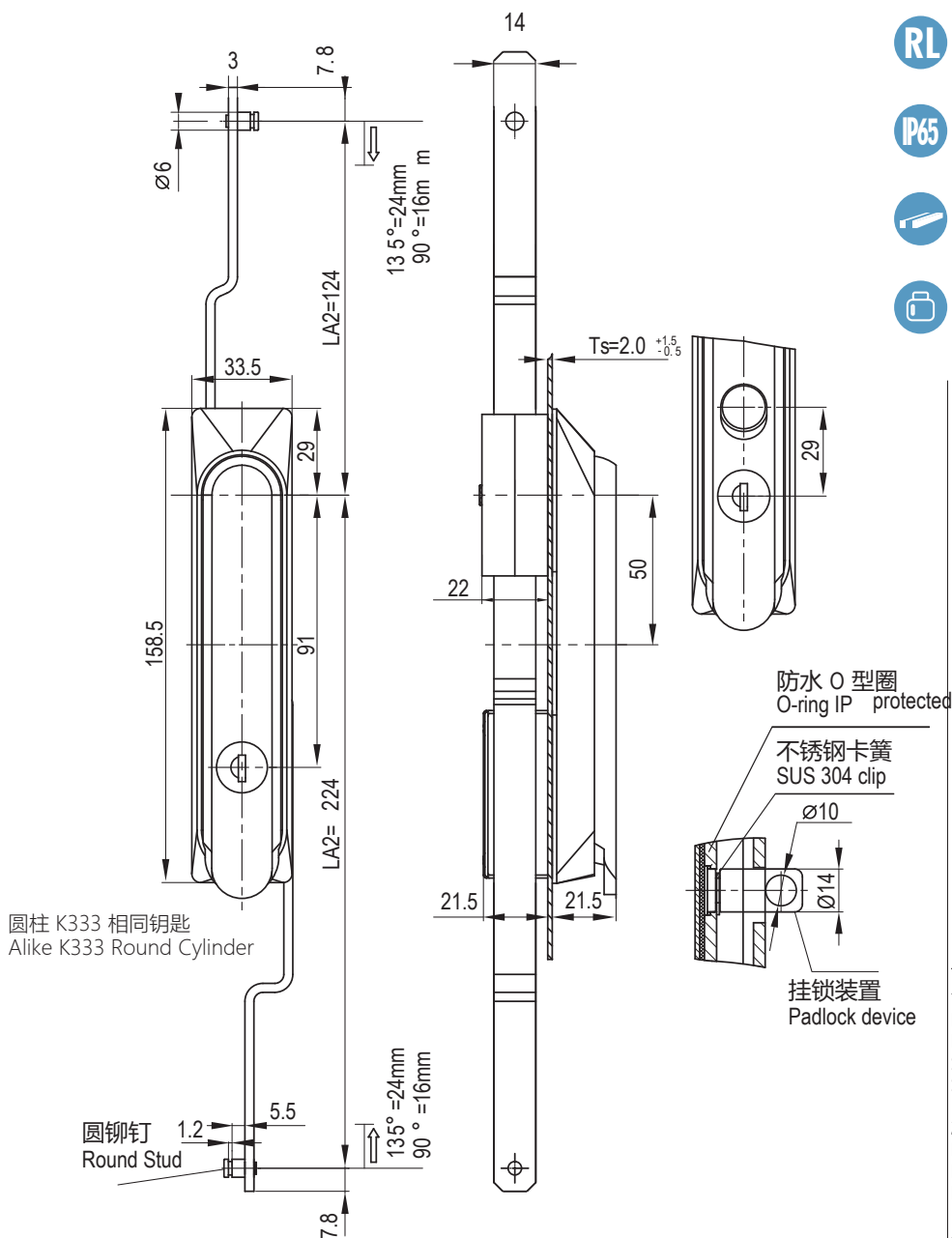

RL

IP65



1. Material and surface treatment:  
Lock body, handle, dust cover : Zamak  
DIN-EN 1774-ZnAl4Cu1  
Steel bolt: iron galvanized  
Sealing ring: EPDM foam.

2. Performance parameters:  
Protection class: IP65  
Handle bearing tension value:  $\leq 400\text{N}$   
Handle bearing torque value:  $\leq 35\text{N}\cdot\text{m}$

4. Remarks:  
Optional dedicated key  
CH751 key optional  
Can be equipped with stainless steel padlock  
Default K333 key

1. 材质及表面处理:  
锁体, 手柄, 防尘盖: 5# 锌合金喷塑黑  
钢栓: 铁镀锌  
密封圈: EPDM 发泡胶。

2. 性能参数:  
防护等级: IP65  
手柄承载拉力值:  $\leq 400\text{N}$   
手柄承载扭矩值:  $\leq 35\text{N}\cdot\text{m}$

4. 备注:  
专用钥匙可选  
CH751 钥匙可选  
可配不锈钢挂锁  
默认 K333 钥匙

锁芯 Cylinder style	Version B( 两点拉杆型 2Prod control)		Version C( 三点拉杆型 3Prod control)	
	有防尘盖 With Dust Cap		无防尘盖 Without Dust Cap	
圆柱 K333 相同钥匙 Alike K333 Round Cylinder	A-1201-2001-C-40	A-1201-2001-NC-40	A-1201-3001-C-40	A-1201-3001-NC-40