

**B-1312**

L handle lock

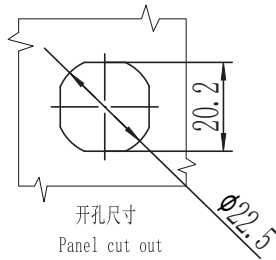
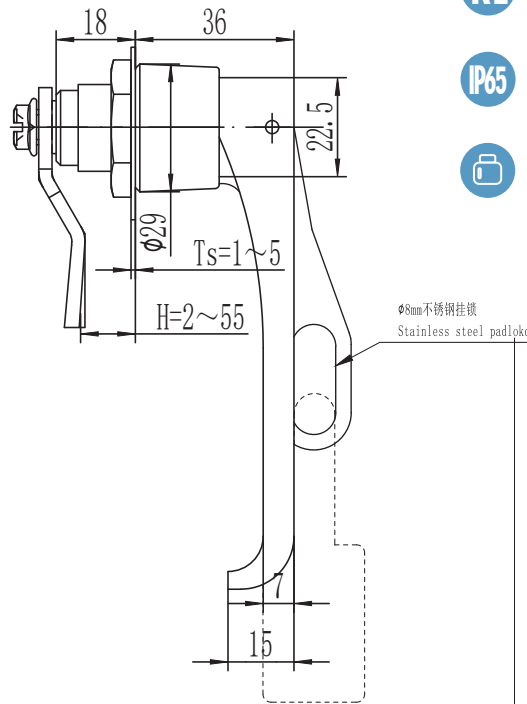
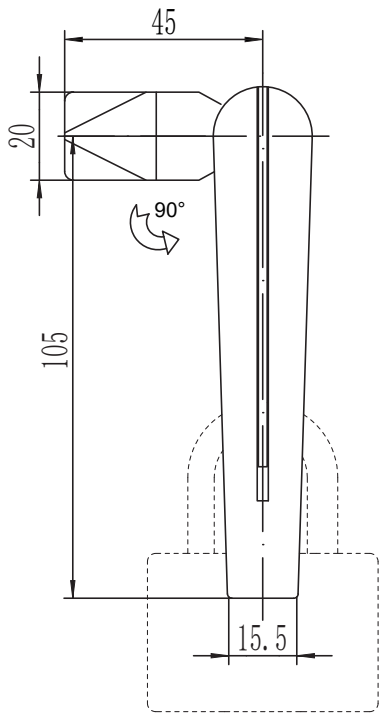

RL

IP65



1. Material and surface treatment:  
Lock body, handler: Zamak DIN-EN 1774-ZnAl4Cu1 or SUS304  
Steel bolt: iron galvanized or SUS304  
Sealing ring: EPDM foam

2. Performance parameters:  
Protection class: IP65

3. Remarks:  
Stainless steel Padlockable on request

1. 材质及表面处理:  
锁体, 手柄: 5# 锌合金 SUS304  
螺栓: 铁镀锌或 SUS304  
密封圈: EPDM 发泡胶。

2. 性能参数: 防护等级: IP65

3. 备注:  
配不锈钢挂锁

锌合金 Zinc alloy		不锈钢 Stainless steel
喷塑黑 Powder coating black	亮铬 Bright chrom	
B-1312-40	B-1312-30	B-1312-A1