

B-1714 push to close latch knob latch

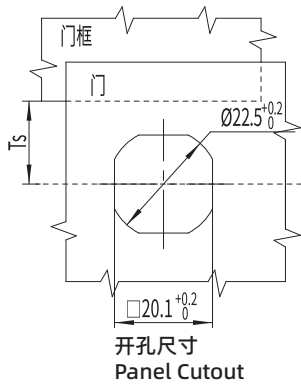

锁芯 Cylinder

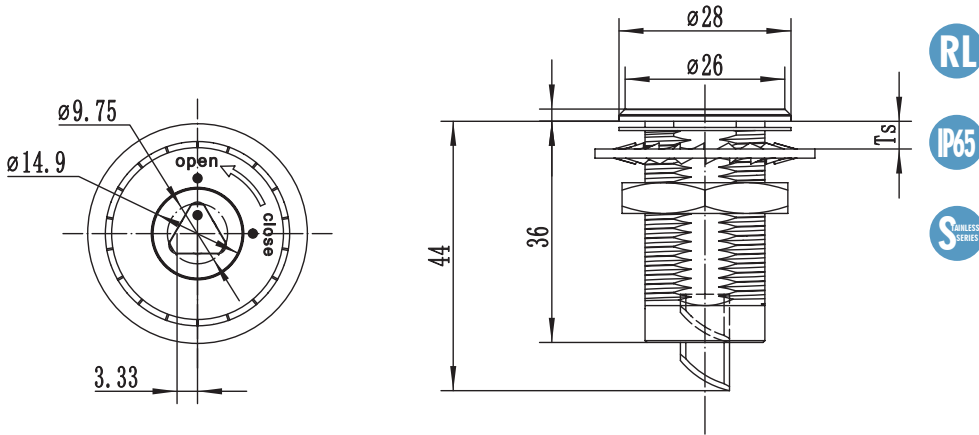
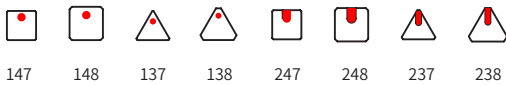

选型 Model selection

锁芯选型
Lock cylinder selection

B-1714-SX-A1L

L 代表左锁 顺时针旋转锁紧
L represents clockwise rotation and locking of the left lock
R 代表右锁 逆时针旋转锁紧
R represents the counterclockwise rotation and locking of the right lock

旋转 Rotate



1. Material and surface treatment:
Lock body, handle, dust cover : SUS304 or SUS316
Sealing ring: EPDM foam.

2. Performance parameters:
Protection class: IP65
Unlocking torque: $\leq 0.79\text{N}\cdot\text{M}$
Ultimate load: 700N
Tensioning and stretching amount: 8.8mm

3. Installation instructions:
Fixed nut torque 17N. M
Applicable door panel thickness: 1-15mm

1. 材质及表面处理:
锁体: SUS304 或 SUS316
密封圈: EPDM发泡胶。

2. 性能参数:
防护等级: IP65
解锁扭矩: $\leq 0.79\text{N}\cdot\text{M}$
极限载荷: 700N
拉紧伸缩量: 8.8mm

3. 安装说明:
固定螺母扭矩 17N.M
适用门板厚度: 1-15mm