

## A-1117

## Swing handle lock

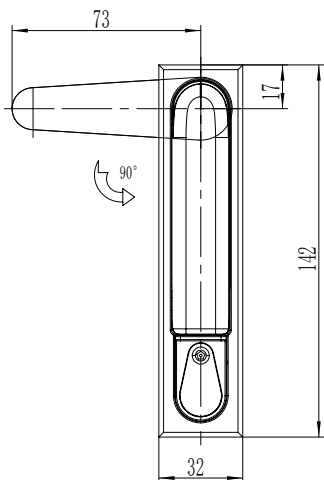

方形 Square

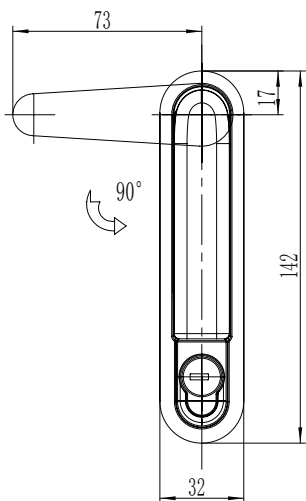
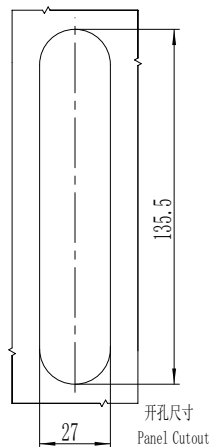
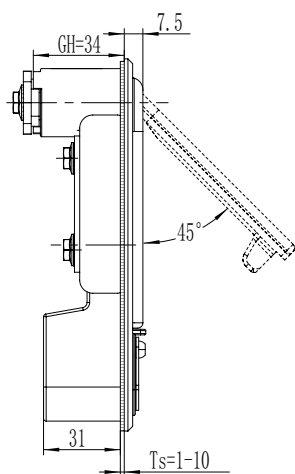

圆型 Round type

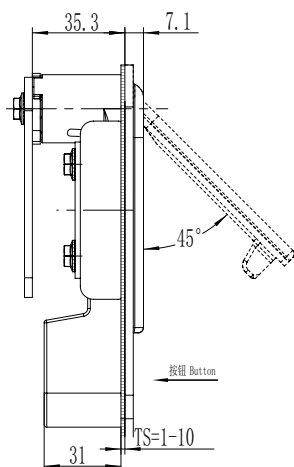

RL

IP65



1. Material and surface treatment:  
Lock body, handle dust cover : Zamak DIN-EN 1774-ZnAl4Cu1  
Steel bolt: iron galvanized  
Sealing ring: EPDM foam.

2. performance parameter  
Protection level: IP65  
Handle bearing tension value:  $\leq 250\text{N}$   
Handle bearing torque value:  $\leq 30\text{N}\cdot\text{m}$   
Maximum static load: 300N

3. Function Description:  
Open the handle upwards and rotate it 90° to achieve opening  
Can be equipped with a padlock

3. Remarks:  
Optional dedicated key  
Default K333 key

1.材质及表面处理:  
锁体, 手柄: 5#锌合金  
钢栓: 铁镀锌  
密封圈: EPDM发泡胶。

2.性能参数  
防护等级: IP65  
手柄承载拉力值:  $\leq 250\text{N}$   
手柄承载扭矩值:  $\leq 30\text{N}\cdot\text{m}$   
最大静载荷: 300N

3.功能描述:  
手柄向上打开, 90°旋转实现开启  
可带挂锁

3.备注:  
专用钥匙可选  
默认 K333钥匙

如需获得产品 3D 模型图, 请联系 WWW.FORND.COM

| 外形 Shape         | 喷塑黑 Powder coating black | 纳米喷漆 (银亚光) NM spray painting (matte silver) | 不锈钢 Stainless steel 拉丝抛光 polishing |
|------------------|--------------------------|---|------------------------------------|
| 方形 Square        | A-1117-10-40             | A-1117-10-50                                | A-1117-10-A1                       |
| 圆形 Circular type | A-1117-20-40             | A-1117-20-50                                | A-1117-20-A1                       |