

连杆型旋转把手 Rod Control Swinghandle

A-1200 Rod Control Swinghandle

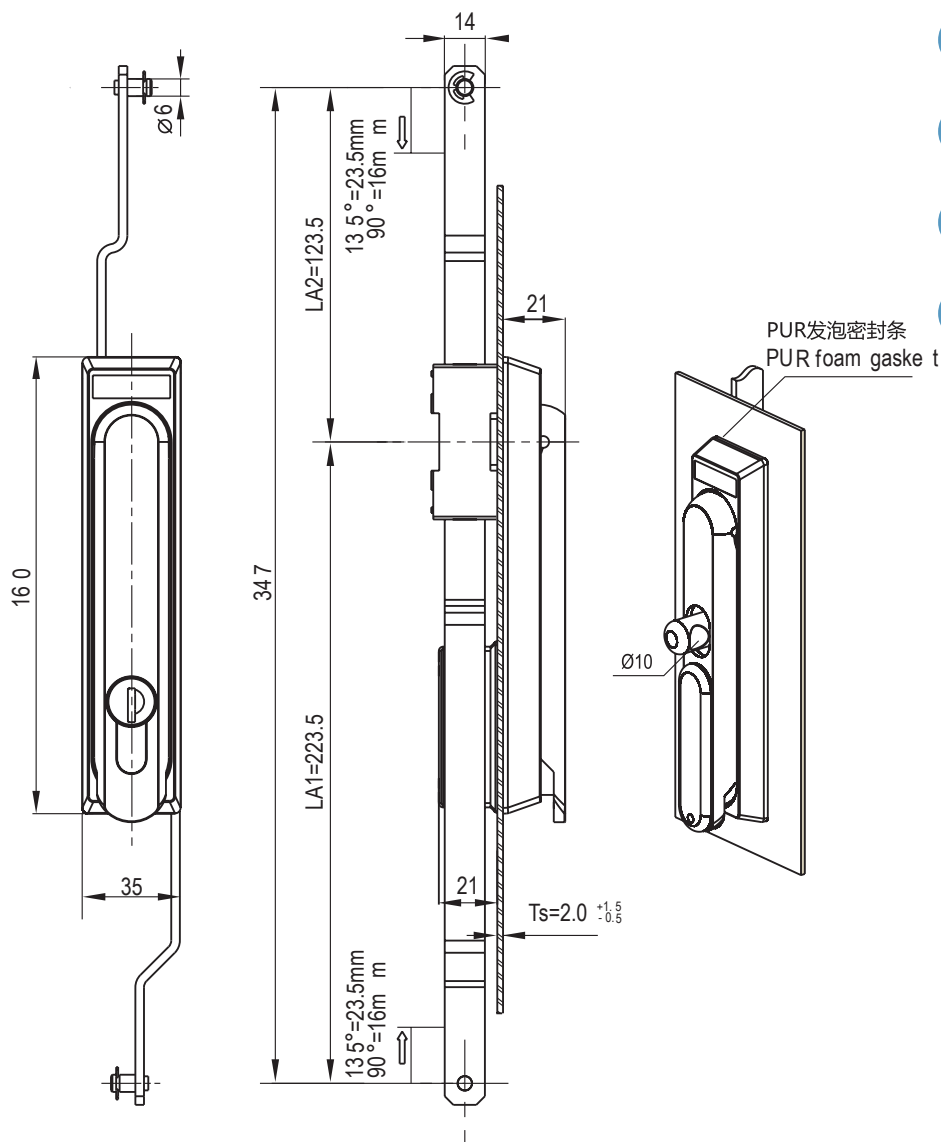

RL

IP65

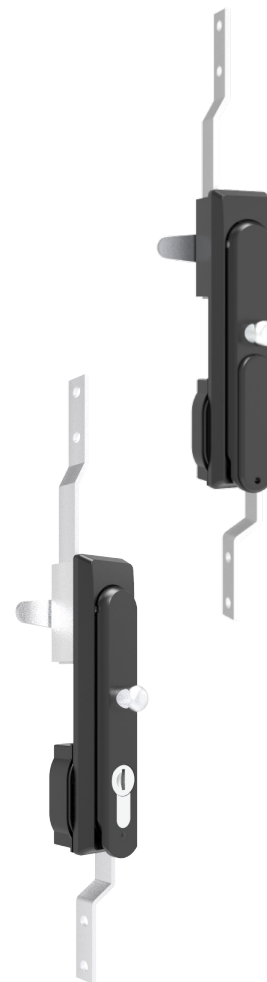

1. Material and surface treatment:
Lock body, handle, dust cover : Zamak
DIN-EN 1774-ZnAl4Cu1
Steel bolt: iron galvanized
Sealing ring: EPDM foam.

2. Performance parameters:
Protection class: IP65
Handle bearing tension value: ≤ 400N
Handle bearing torque value: ≤ 35N.m

4. Remarks:
Optional dedicated key
CH751 key optional
Can be equipped with stainless steel padlock
Default K333 key

1. 材质及表面处理:
锁体, 手柄, 防尘盖: 5# 锌合金喷塑黑
钢栓: 铁镀锌
密封圈: EPDM 发泡胶。

2. 性能参数:
防护等级: IP65
手柄承载拉力值: ≤ 400N
手柄承载扭矩值: ≤ 35N.m

4. 备注:
专用钥匙可选
CH751 钥匙可选
可配不锈钢挂锁
默认 K333 钥匙

锁芯 Cylinder style	Version B(两点拉杆型 2PProd control)		Version C(三点拉杆型 3PProd control)	
	有防尘盖 With Dust Cap	无防尘盖 Without Dust Cap	有防尘盖 With Dust Cap	无防尘盖 Without Dust Cap
半圆柱 相同钥匙 K333 Alike K333 Proble Round Cylinder	A-1200-2P01-C-40	A-1200-2P01-NC-40	A-1200-3P01-C-40	A-1200-3P01-NC-40
双翅 4mm (Double Bit 4mm)	A-1200-2P02-C-40	A-1200-2P02-NC-40	A-1200-3P02-C-40	A-1200-3P02-NC-40
三角锁芯 8mm (Triangular 8mm)	A-1200-2P03-C-40	A-1200-2P03-NC-40	A-1200-3P03-C-40	A-1200-3P03-NC-40
四方锁芯 7mm (Square 7mm)	A-1200-2P04-C-40	A-1200-2P04-NC-40	A-1200-3P04-C-40	A-1200-3P04-NC-40